



Refractories for Blast Furnace







The chemical physical properties of the products

The tables hereinafter show the main average properties of the products. These properties, verified by internal testings, are merely indicative and should not be used as guaranteed values for tender technical specifications.

In case of special requirements, technical specifications containing the guaranteed values and those detailing the various properties may be agreed with the Customer during sales negotiations.

The individual properties are determined according to ISO Recommendations and Standards Pre Recommendations (Pre Recommendations - Revision June 1990).

In default of recommendations from the two above Bodies or should special tests be required, special rules or company methods may be adopted. Such rules and methods shall be specified and agreed upon with the Customer.

Brick dimensions (shapes)

The refractory bricks are produced in the great many shapes required for the correct lining of each plant in which they are to be installed.

SANAC is able to produce both the shapes envisaged by the main international standardization rules and the special shapes for specific uses.

The Design Service is at the Customer's disposal to provide him with the most profitable solutions.



Dimensional Tolerances

The dimensional tolerances of bricks generally conform with the PRE/R23 Recommendation (“Dimensional tolerances of dense and insulating refractory products”).

Particular tolerances, if any, should be indicated at the time of the en-quiry and be the subject of tender technical specifications.

Sorting and checkig

The bricks, removed from the furnaces, after heat treatment, are classified and checked (“Inspection by attributes”) with respect to their dimensional characteristics and their outward appearance (fissures, cracks, chipped edges, stains, etc.).

Furthermore, on a statistical basis, controls are carried out on the chemical-physical properties, such as mainly:

- Chemical analysis
- Refractoriness
- Bulk density
- Porosity
- Cold crushing strength
- Modulus of rupture
- Refractoriness under load (R.U.L.)
- Linear thermal expansion
- Permanent linear change
- Thermal shock
- Permeability to gases.

These tests are made on a routine basis in the Quality Control laboratory of each works.

Special test are carried out by the Central Laboratory of Research. The production control is effected in accordance with Assurance Quality System.

Quality



The qualitative standard of a refractory material has reached such a determinant influence level as to condition the operational results. It is therefore evident the absolute necessity to carry into effect a severe policy of quality in manufacturing.

This policy is imposed by the ever-increasing stresses to which the material is subjected during the operation as well as by the level of high specialization and differentiation reached by refractory products.

In the manufacturing process, therefore all those measures are adopted which are necessary to attain the right quality level and to keep it constant, namely:

- precise processing instructions for each phase of the production process and detailed quality manuals from the raw material control up to the finished products;
- provision of a structure able to produce according to the criteria of the "Quality Assurance".

All our works, as well as all our laboratories, are conform to Assurance Quality System in accordance with UNI EN ISO 9001, certified by DNV as shown at side.

Services

RESEARCH AND DEVELOPMENT

Industrial progress, greatly advances in the latest years, imposes more and more severe conditions to refractory linings and demands materials of more and more sophisticated qualities in order to meet the requirements of better performances under every technical and economical aspect.

In order to take active part in this quick developing process, in addition to the individual Works Laboratories charged with the production control and testing (from raw materials to finished products), SANAC owns a Central Laboratory of Research which employs several highly-qualified specialists.

This unit is fitted with all the most modern equipments necessary to the most advanced technological requirements in the sector, it carries out its activity in applied research, in the production and development of new products, in the improvement of the existing products and relevant manufacturing processes. The Central Laboratory of Research is in Vado Ligure.

DESIGN ENGINEERING AND TECHNICAL ASSISTANCE

The Design Engineering and Technical Assistance Service constitutes an integrated system set up in order to cover all stages from design engineering up to construction and installation. Design engineering is carried out with the C.A.D. system. The Service is in fact a company sector whose function is to find out and solve all problems connected with refractory materials.

It operates on site in dose touch with the user and studies the most valid solutions under the technical and economical aspect, thus reaching a precise detailed design engineering of the individual components of a lining.

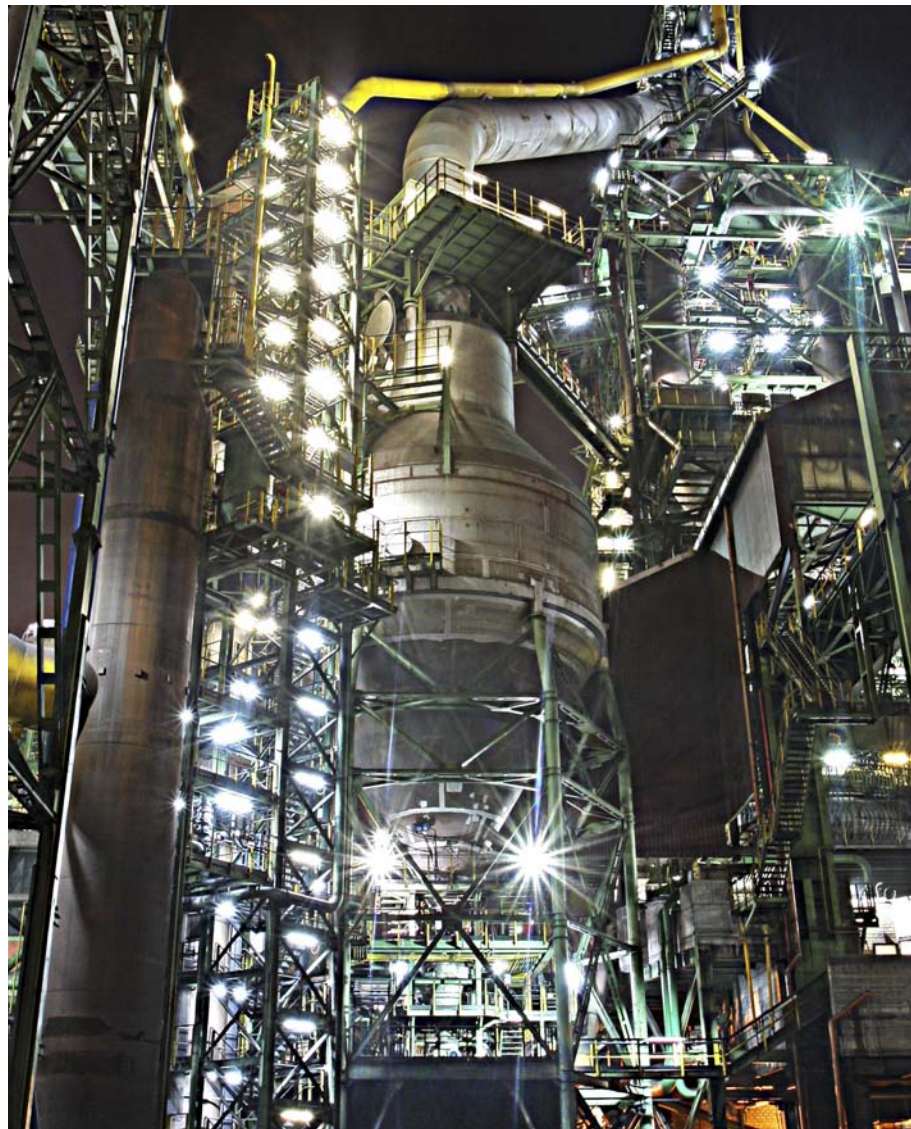



Know-how

Sanac technology is active all over the world. In fact, SANAC puts its own experience at the disposal of other producers of refractory materials.

Many are the know-how agreements stipulated with foreign countries. The collaboration supplied by the Company mainly consists of:

- setting out of the most up-to-date production cycles;
- supervision of plant final design engineering;
- supervision of plant erection and start-up;
- supply of complete know-how;
- training of the Customer's technical personnel in order to hit the production targets.

From Company's profile it is possible to identify the principles which are at the base of its activity and which explain its constant progress in a world-wide refractory industry.



Blast furnace

SANAC started the production of refractories for blast furnaces since 1957. Up to to-day, lining materials have been supplied to about 50 blast furnaces in Italy and abroad always achieving excellent results and acquiring a solid reputation among the users.

It is well known that in the last ten years this sector has considerably developed. Volumes above 4500 m³, temperatures from 2.000 to 2.200 °C around tuyeres, total pressure of about 5 kg/ cm² on the bottom, of 2 to 2,5 kg/cm² at the top.

Pre-treatment of raw materials, oxygen enrichment, injection of coal, heavy oil and tar are some indications on the extreme operating conditions to which the refractory materials are subjected. SANAC has carried out a widespread research with the aim of obtaining a constant optimization of all the lining components.

On the basis of operational tests and through the practical results attained and constant research, new high-quality products have been obtained together with the steady improvement of fireclay products commonly in use.

At the same time researches have been made to improve both cement qualities, with the purpose of making them suitable for the new more severe operating conditions, and new types of bricks as well as of filling materials for cooling elements, refractory lining and metal structure.

Furthermore, special unshaped materials are available for construction, repair and operation (castables, gunning and injection and tap-hole masses).



Sanac's works

- 1. 13045 GATTINARA (VC)**
Corso Garibaldi, 321
Phone +39 0163 824711
Fax +39 0163 89321
- 2. 17047 VADO LIGURE (SV)**
Via Manzoni, 10
Phone +39 019 28951
Fax +39 019 882555
- 3. 54100 MASSA**
Via Dorsale, 7
Zona Industriale
Phone +39 0585 799001
Fax +39 0585 799031
- 4. 09032 ASSEMINI (CA)**
Loc. Grogastu
Zona Ind. Macchiareddu
Phone +39 070 24651
Fax +39 070 247058





Products

Refractories
for Blast Furnace



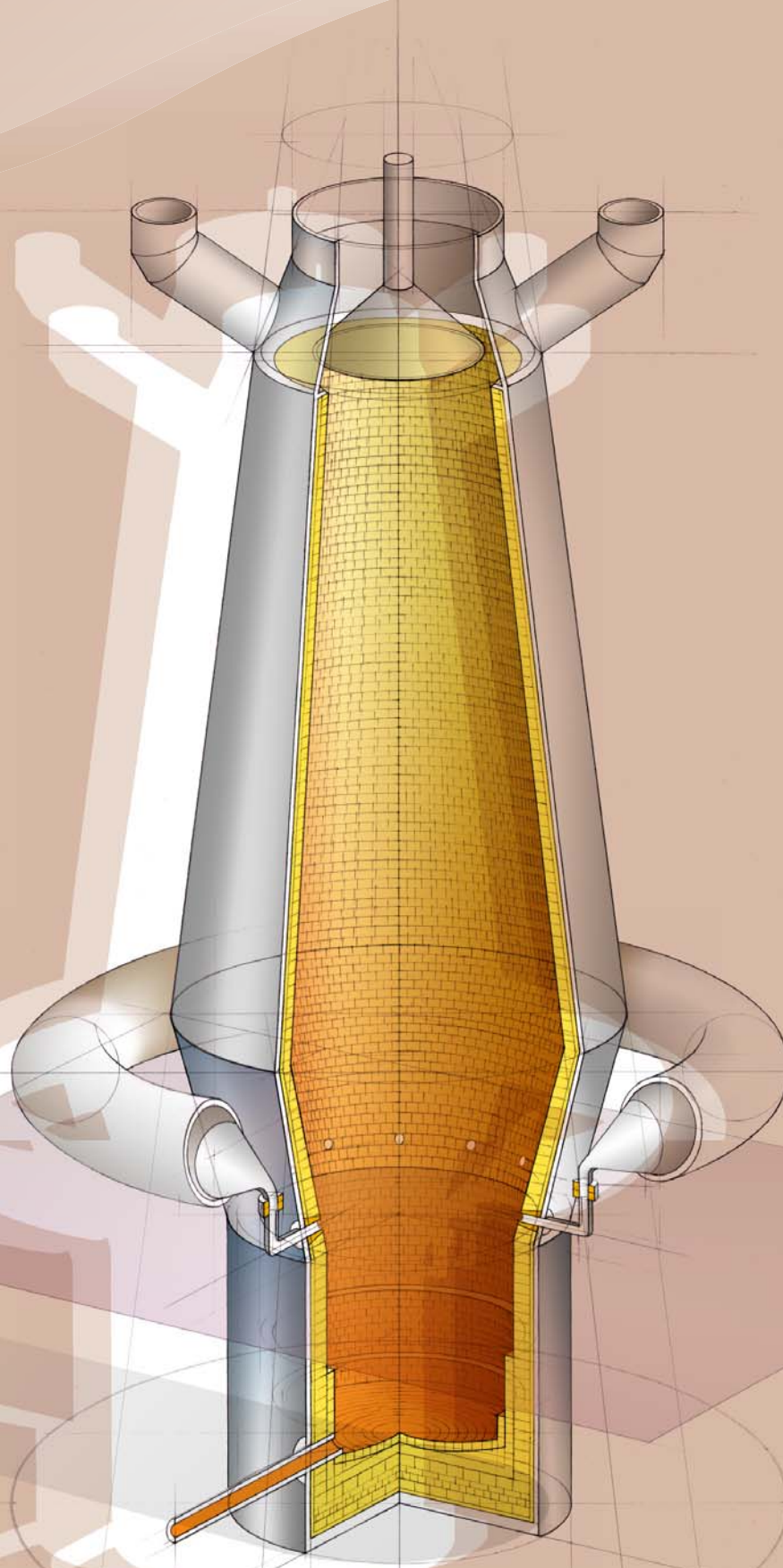

Blast Furnace shapes

65 MM THICKNESS

Code	Description	Dimensions (mm)	Volume (dm ³)	Pieces per pallet
XT/4	key	172 x 152 / 148 x 65	1,68	-
XT65	key	172 x 152 / 140 x 65	1,63	-
AX 5	key	230 x 152 / 136 x 65	2,15	234
AX152-5	key	230 x 152 / 147 x 65	2,24	-
A	straight	230 x 152 x 65	2,27	216
PX 18	key	265 x 152 / 134 x 65	2,46	180
PA	straight	265 x 152 x 65	2,61	180
BX 23	key	300 x 150 / 127 x 65	2,70	180
BX 6	key	300 x 150 / 146 x 65	2,90	-
3	straight	300 x 150 x 65	2,92	180
EX 3	key	345 x 152 / 127 x 65	3,12	153
ER	straight	345 x 152 x 65	3,40	153
EX 8	key	345 x 154 / 146 x 65	3,36	-

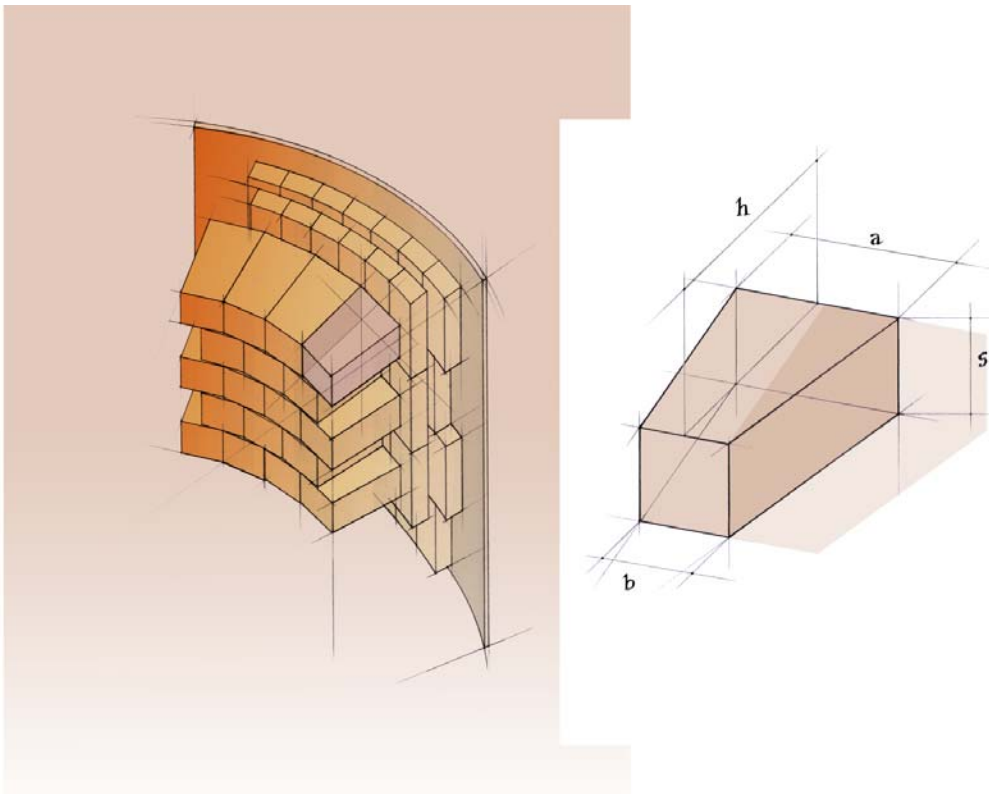

76 MM THICKNESS

Code	Description	Dimensions (mm)	Volume (dm ³)	Pieces per pallet
XR/76	key	115 x 172 / 163 x 76	1,46	-
XH/TR/76	straight	172 x 152 x 76	1,99	-
XT76	key	172 x 152 / 140 x 76	1,91	-
XT/22	key	172 x 152 / 130 x 76	1,84	-
R/76	straight	230 x 115 x 76	2,01	-
76X3		230 x 115 / 89 x 76	1,78	-
76X1	key	230 x 115 / 70 x 76	1,78	-
HX152-5	key	230 x 152 / 147 x 76	2,61	-
HX 3	key	230 x 152 / 122 x 76	2,40	-
HX 5	key	230 x 152 / 136 x 76	2,52	208
H	straight	230 x 152 x 76	2,65	192
XH/76	key	265 x 172 / 160 x 76	2,88	160
PX18/76	key	265 x 152 / 134 x 76	2,88	160
PH	straight	265 x 152 x 76	3,06	160
X 6	key	300 x 150 / 146 x 76	3,40	-
X 23	key	300 x 150 / 127 x 76	3,16	152
3/76	straight	300 x 150 x 76	3,42	160
RX 2T	key	300 x 152 / 116 x 76	3,05	-
RX 3	key	345 x 152 / 127 x 76	3,65	136
RX 2	key	345 x 152 / 111 x 76	3,45	-
1L76	straight	345 x 115 x 76	3,02	-
RR	straight	345 x 152 x 76	3,98	136
RX 8	key	345 x 154 / 146 x 76	3,93	-
4H	straight	400 x 152 x 76	4,62	-
4HX/24	key	400 x 164 / 140 x 76	4,62	-
4L76	straight	414 x 300 x 76	9,44	-
3X-30	key	450 x 160 / 130 x 76	4,96	-
3X-56	key	450 x 160 / 104 x 76	4,51	-

77 MM THICKNESS

Code	Description	Dimensions (mm)	Volume (dm ³)	Pieces per pallet
AX5/77	key	230 x 152 / 136 x 77	2,55	-
BX23/77	key	300 x 150 / 127 x 77	3,20	-
EX3/77	key	345 x 152 / 127 x 77	3,71	-
HX152-5/77	key	230 x 152 / 147 x 77	2,65	-
BX 6/77	key	300 x 150 / 146 x 77	3,44	-
EX 8/77	key	345 x 154 / 146 x 77	3,98	-

85 MM THICKNESS

Code	Description	Dimensions (mm)	Volume (dm ³)	Pieces per pallet
XT85	key	172 x 152 / 140 x 85	2,13	-
AX5/85	key	230 x 152 / 136 x 85	2,81	182
A/85	straight	230 x 152 x 85	2,97	168
BX23/85	key	300 x 150 / 127 x 85	3,53	140
3/85	straight	300 x 150 x 85	3,82	140
EX3/85	key	345 x 152 / 127 x 85	4,09	119
ER/85	straight	345 x 152 x 85	4,45	119

98 MM THICKNESS

Code	Description	Dimensions (mm)	Volume (dm ³)	Pieces per pallet
XT/98	key	172 x 152 / 140 x 98	2,46	-
AX5/98	key	230 x 152 / 136 x 98	3,24	156
A/98	straight	230 x 152 x 98	3,42	144
PX18/98	key	265 x 152 / 134 x 98	3,71	120
PA/98	straight	265 x 152 x 98	3,95	120
BX23/98	key	300 x 150 / 127 x 98	4,07	120
3/98	straight	300 x 150 x 98	4,41	120
EX3/98	key	345 x 152 / 127 x 98	4,72	102
ER/98	straight	345 x 152 x 98	5,14	102

Safety lining bricks

PRODUCT		AF 23 I	AFO 44 I	LF 62	SG 60 S
Main component		Chamotte		Andalusite	Andalusite Bauxite
CHEMICAL ANALYSIS (on raw materials oxides)					
Al ₂ O ₃	%	45,0	46,0	59,0	67,5
SiO ₂		51,0	49,5	36,5	29,0
Fe ₂ O ₃		1,5	1,5	0,9	1,4
TiO ₂		1,5	1,5	0,4	1,8
PHYSICAL PROPERTIES					
Refractoriness	SK	> 34	34	> 37	> 37
Density	Kg/dm ³	2,38	2,36	2,56	2,59
Apparent porosity	%	13,0	15,5	12,5	18,0
Cold crushing strenght	Kg/cm ²	> 500	650	1.000	750
Modulus of rupture at 1.500°C	Kg/cm ²	20	22	-	20
Refractoriness under load t 0,5	°C	1.460	1.360	1.600	1.530
Reversible expansion at 1.000°C	%	0,64	0,58	-	0,62
Permanent linear change, 5 hours	at 1.500°C %	± 0,5	< ± 0,5	< ± 0,5	< ± 1
Thermal conductivity at 500°C	W/mK	1,40	1,40	1,43	1,44
Thermal conductivity at 1.000°C		1,52	1,49	1,46	1,45

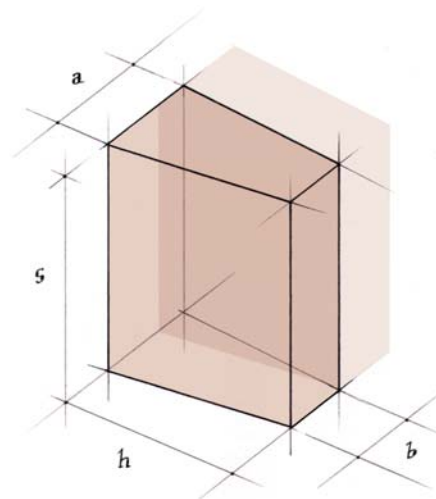
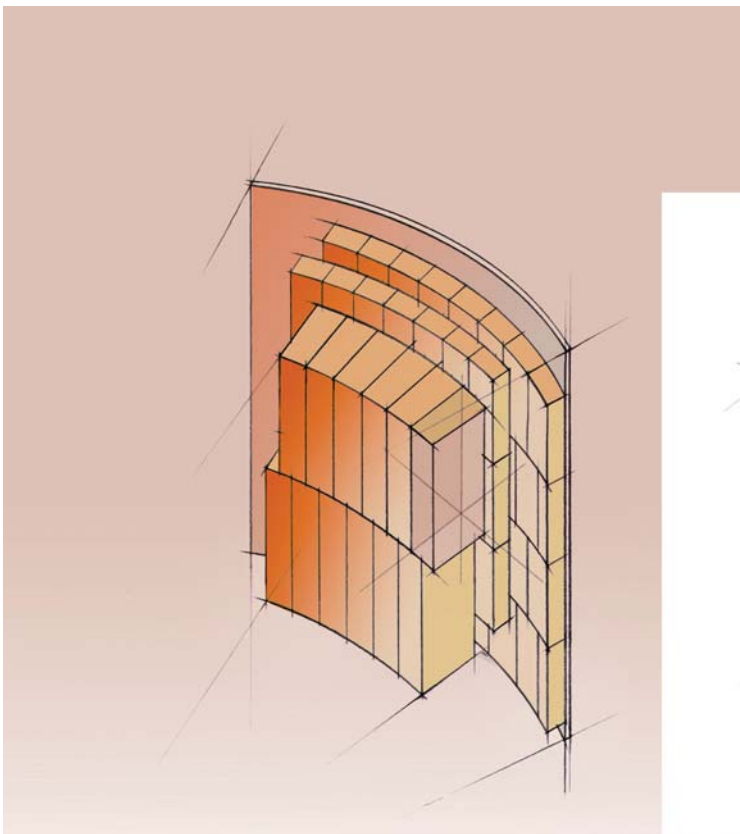

Wear lining bricks

PRODUCT		EP I	AF 4 I	AF 26 I	AF 26 LI	AF 60	AF 60/T	AF 60/T/LI	AF 80
Main component		Chamotte	Chamotte	Chamotte	Chamotte	Alumina Chamotte	Mullite		Alumina Andalusite
CHEMICAL ANALYSIS (on raw materials oxides)									
Al ₂ O ₃	%	43,5	45,0	45,0	46,5	56,0	65,0	66,0	80,0
SiO ₂		52,5	51,0	50,5	50,0	40,0	32,0	32,0	18,5
Fe ₂ O ₃		1,2	1,2	1,1	0,9	1,1	0,6	0,5	0,5
TiO ₂		1,1	1,7	1,7	1,9	2,1	0,5	0,4	0,2
PHYSICAL PROPERTIES									
Refractoriness	SK	34	34	35	35	37	> 37	> 37	> 37
Density	Kg/dm ³	2,33	2,40	2,38	2,40	2,50	2,47	2,50	2,85
Apparent porosity	%	19,0	13,5	13,0	14,0	16,0	14,5	14,0	13,5
Cold crushing strenght	Kg/cm ²	> 450	> 500	> 550	> 550	> 650	> 800	> 800	> 800
Modulus of rupture at ambiental temperature	Kg/cm ²	60	120	130	130	100	150	150	-
Refractoriness under load t 0,5	°C	1.400	1.460	1.470	1.480	1.470	1.510	1.520	1.700
Creep deformation under 2 Kg/cm ² , 50 hours	at °C %	1.150 <1	1.300 <1	1.300 <1	1.350 <1	1.350 <1	1.400 <1	1.400 <1	1.500 <1
Reversible expansion at 1.000°C	%	0,60	0,65	0,67	0,68	0,75	0,76	0,76	0,65
Permanent linear change, 5 hours	at °C %	1.300 ± 0	1.600 < ± 1	1.600 < ± 1	1.600 < ± 1	1.600 < ± 1	1.600 < ± 1	1.600 < ± 1	1.500 < 0,5
Thermal conductivity at 500°C	W/mK	1,28	1,40	1,42	1,45	1,47	1,59	1,58	2,20
Thermal conductivity at 1.000°C		1,39	1,53	1,53	1,53	1,59	1,69	1,70	2,20
Carbon monoxide disintegration		Affected	Unaffected	Unaffected	Unaffected	Unaffected	Unaffected	Unaffected	-
Thermal shocks	nr	≥ 20	≥ 5	≥ 5	≥ 5	≥ 10	≥ 10	≥ 10	-

Wear lining bricks

PRODUCT		SMC SID	SMC SID IB	AF-70 CRP	AL 91 I	AF 80	AF 62	AF 62 X	AF 70 CR
Main component		Andalusite		Corundum mullite	Alumina	Alumina andalusite			Mullite alumina
CHEMICAL ANALYSIS (on raw materials oxides)									
Al ₂ O ₃	%	68,0	68,0	73,0	91,0	80,0	62,0	62,0	72,0
SiO ₂		29,0	31,0	20,5	8,0	18,5	34,5	34,5	27,0
Fe ₂ O ₃		0,6	0,7	0,6	0,2	0,5	0,7	0,7	0,3
TiO ₂		0,7	-	1,2	-	0,2	0,3	0,3	0,3
C		-	5,5	-	-	-	-	-	5,8
PHYSICAL PROPERTIES									
Refractoriness	SK	37	37	> 37	> 40	> 37	> 37	> 37	> 37
Density	Kg/dm ³	2,35	2,50	2,79	3,00	2,85	2,64	2,58	2,55
Apparent porosity	%	24,5	5,0	12,0	15,5	13,5	13,5	4,2	15,5
Cold crushing strength	Kg/cm ²	500	600	> 900	> 1.200	800	1.000	1.000	> 750
Modulus of rupture at room temperature		100	-	170	130	-	-	-	170
Refractoriness under load t 0,5	°C	1.600	1.600	1.550	1.700	1.700	1.610	1.610	1.600
Creep deformation under 2 Kg/cm ² , 50 hours	at °C %	1.400 < 1	-	1.450 < 1	1.500 < 1	1.500 < 1	1.400 < 1	1.400 < 1	1.450 < 1
Reversible expansion at 1.000°C	%	0,60	0,59	0,75	0,71	0,65	0,76	0,76	0,62
Permanent linear change, 5 hours	at °C %	1.600 < ± 0,5	1.600 < ± 0,5	1.600 < ± 0,5	1.600 < 0,5	1.500 < 0,5	1.600 < ± 0,5	1.600 < ± 0,5	1.600 < 0,5
Thermal conductivity at 500°C	W/mK	1,39	-	1,59	2,78	2,20	1,39	-	1,59
Thermal conductivity at 1.000°C		1,47	-	1,69	2,55	2,20	1,51	-	1,68
Carbon monoxide disintegration	nr	Unaffected	Unaffected	Unaffected	Unaffected	Unaffected	Unaffected	-	Unaffected
Thermal shocks	nr	≥ 15	-	≥ 8	≥ 30	-	-	-	-

Cements

			Chemical bonded ready			Chemical bonded dry				Air setting dry		Heating setting dry	
PRODUCT			BONDLOK			SINTBOND				MF		CEM	
			AF	KB	Z	80	ZD	A100D	A100B	40	52	40	72
Main component			Chamotte	Corindone	Corindone	Bauxite	Corindone	Corindone	Corindone	Chamotte	Chamotte	Chamotte	Mullite
					Chrome oxide	Corundum	Chrome oxide				Bauxite		
CHEMICAL ANALYSIS (on raw materials oxides)													
Al ₂ O ₃	%	PRE R24	46,0	79,5	78,0	70,5	76,0	87,0	98,0	41,0	52,0	45,0	73,0
SiO ₂		PRE R24	48,0	1,05	12,0	20,0	14,2	8,5	1,3	53,0	42,5	51,0	26,0
Fe ₂ O ₃		PRE R24	3,0	3,2	3,5	1,4	3,0	3,3	-	-	0,2	-	-
TiO ₂		PRE R24	-	-	5	-	5	-	-	-	-	-	-
C		PRE R24	-	-	-	-	-	-	-	-	3,5	1,5	-
PHYSICAL PROPERTIES													
Grain size max.	mm	PRE R25	0,2	0,2	0,2	0,5	0,2	0,2	0,2	0,5	0,5	0,2	0,5
Fraction < 0,063 mm min.	%	UNI2231/ 2232	65	65	60	65	60	60	50	65	65	65	65
Refractoriness	Seeger cone	ISR 528	35	>37	>37	35	>37	>37	>37	26	29	33	37
Bonding strength after heating: 24 h at 450°C	Kg/cm ²	(*)	50	80	40	30	40	40	(110) 30	(110) 50	(110) 10	(110) 5	(110) 10
Bonding strength after heating: 5 h at 1.000°C	Kg/cm ²		80	90	100	10	-	60	15	60	10	-	-
Bonding strength after heating: 5 h at 1.400°C	Kg/cm ²		160	200	220	60	150	145	230	90	60	23	150
Water required	%	(*)	-	-	-	18	18	17	16	38	25	33	25
Retentive time water	min.	(*)	>2,00	>1,00	>2,00	1,05	>2,00	>2,00	1,05	1,00	1,00	>2,00	>2,00
Characteristics			Air setting						Heat setting				

(*) Internal method

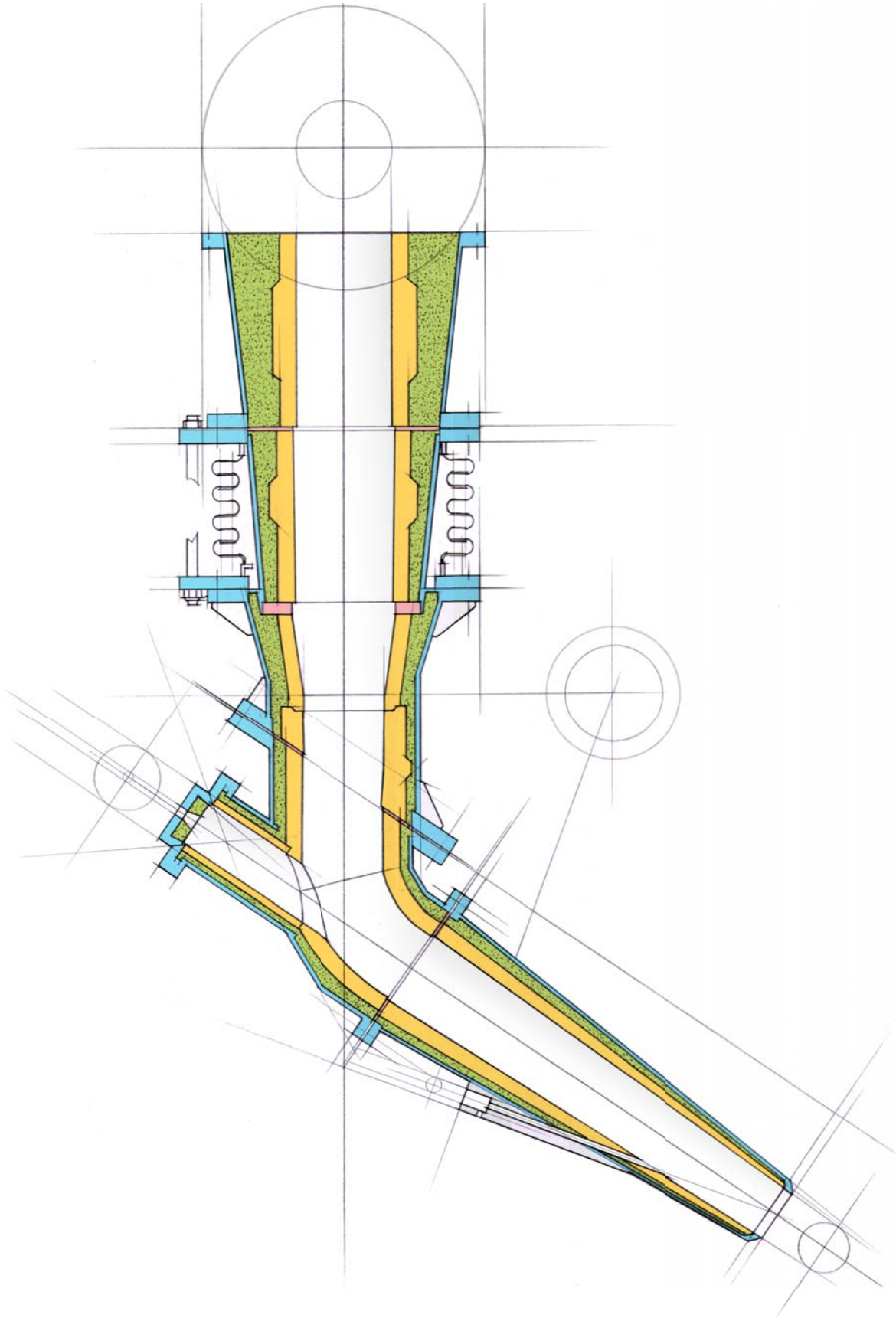

Regular castables

PRODUCT			ALOCAST						
			CF 44	F 44 LI	CH 48	CH 56	CH 57 N	CH 95	CH 98 S
Main component			Chamotte					Bauxite Alumina	Tabular alumina
CHEMICAL ANALYSIS (on raw materials oxides)									
Al ₂ O ₃	%	PRE R24	45,0	51,0	53,0	57,0	55,5	88,0	94,5
SiO ₂		PRE R24	40,0	38,5	41,0	33,5	37,5	4,7	0,5
Fe ₂ O ₃		PRE R24	3,4	1,7	0,8	0,9	0,6	0,8	0,1
TiO ₂		PRE R24	1,0	1,0	0,7	0,9	1,6	-	-
CaO		PRE R24	10,0	7,5	4,0	6,6	4,5	4,0	4,5
PHYSICAL PROPERTIES									
Max. service temperature	°C	(**)	1.350	1.500	1.600	1.450	1.500	1.750	1.800
Quantity required	t/m ³	(**)	2,10	2,17	2,20	2,22	2,17	2,60	2,72
Water required	%	PRE R26	14	12	11	11	11	10	10
P.L.C. after heating: 24 h at 110°C	%	PRE R28	± 0,01	± 0,10	0,00	± 0,05	± 0,05	0,00	0,00
P.L.C. after heating: 5 h at 1.000°C		PRE R28	0,00	-0,30	- 0,20	- 0,20	- 0,20	0,15	0,00
P.L.C. after heating: 5 h at max. service temperature		PRE R28	0,5	1,5	0,8	0,8	- 0,8	- 1,9	0,5
Bulk density after heating: 24 h at 110°C	gr/cm ³	PRE R9	2,17	2,24	2,25	2,29	2,24	2,70	2,78
Bulk density after heating: 5 h at 1.000°C		PRE R9	2,10	2,09	2,05	2,25	2,10	2,68	2,73
Bulk density after heating: 5 h at max. service temperature		PRE R9	2,05	1,89	2,00	2,35	2,15	2,84	2,76
Cold crushing strength after heating: 24 h at 110°C	kg/cm ²	PRE R28	450	850	500	900	450	700	600
Cold crushing strength after heating: 5 h at 1.000°C		PRE R28	350	400	350	700	300	790	500
Cold crushing strength after heating: 5 h at max. service temperature		PRE R28	300	300	600	600	700	830	900
Modulus of rupture after heating: 24 h at 110°C	kg/cm ²	PRE R28	50	60	70	100	60	80	90
Modulus of rupture after heating: 5 h at 1.000°C		PRE R28	25	20	40	30	30	50	70
Modulus of rupture after heating: 5 h at max. service temperature		PRE R28	80	60	100	150	150	250	130
Thermal conductivity at 500°C	W/mK	PRE R32	0,72	0,71	0,74	0,83	0,88	0,94	1,20
Thermal conductivity at 1.000°C		PRE R32	0,77	0,78	0,79	0,85	1,00	1,01	1,50
Characteristics			-	(*)		NOx resistance	-	-	-
Application method						casting			

Low cement castables

PRODUCT			ALOCAST							ALOFLOW			
			LX 50	LX 48	LX 58	071	LX 60	LX 85	SC 16	LX 48	070	SC 70A	
Main component			Chamotte	Mullitic chamotte	Andalusite	Mullitic chamotte		Bauxite	Corundum Silicon	Mullitic chamotte			
CHEMICAL ANALYSIS (on raw materials oxides)													
Al ₂ O ₃	%	PRE R24	48,3	51,5	59,0	59,0	56,5	82,0	75,3	53,0	-	-	
SIC + C		PRE R24	-	-	-	-	-	-	16,9	-	+ 72,0	+ 70,5	
CaO		PRE R24	2,3	1,4	2,4	1,6	2,3	2,3	1,15	1,5	1,5	1,8	
SiO ₂		PRE R24	48,0	44,0	37,0	35,0	38,0	11,5	4,30	43,0	-	-	
Fe ₂ O ₃		PRE R24	0,80	0,80	0,60	1,00	0,90	1,00	0,23	0,65	0,23	0,10	
TiO ₂		PRE R24	1,2	-	0,3	-	1,5	2,4	-	-	-	-	
Metallic addition			Yes	Yes	Yes	Yes	Yes	Yes	No	No	No	No	
PHYSICAL PROPERTIES													
Max. service temperature	°C	(*)	1.500	1.500	1.600	1.650	1.600	1.600	1.600	1.500	1.550	1.500	
Quantity required	t/m ³	(*)	2,35	2,45	2,50	2,48	2,43	2,85	3,08	2,40	2,59	2,58	
Water required	%	PRE R26	5,5	5,0	5,0	5,0	5,0	5,0	5,0	7,0	7,0	7,0	
P.L.C. after heating: 5 h a 1.000°C		PRE R28	- 0,45	- 0,20	± 0,04	- 0,40	- 0,10	- 0,20	- 0,05	± 0,20	- 0,12	- 0,20	
P.L.C. after heating: 5 h at max. service temperature		PRE R28	+ 0,20	+ 0,20	0,60	0,68	+ 0,80	1,60	- 0,30	- 0,20	- 0,62	-	
Bulk density after heating: 24 h at 110°C	gr/cm ³	PRE R9	2,38	2,48	2,69	2,53	2,47	2,90	3,10	2,45	2,65	2,66	
Bulk density after heating: 5 h at 1.000°C		PRE R9	2,36	2,46	2,66	2,57	2,44	2,86	3,09	2,42	2,64	2,63	
Bulk density after heating: 5 h at max. service temperature		PRE R9	2,37	2,45	2,61	2,51	2,41	2,80	3,15	2,41	2,72	-	
Cold crushing strength after heating: 24 h at 110°C	kg/cm ²	PRE R28	1.000	1.000	1.300	1.050	1.100	1.300	420	1.250	550	850	
Cold crushing strength after heating: 5 h at 1.000°C		PRE R28	1.100	1.000	900	1.300	1.000	1.200	1.100	1.000	1.290	1.300	
Cold crushing strength after heating: 5 h at 1.000°C		PRE R28	900	1.300	1.300	1.250	1.000	900	1.000	1.350	1.700	-	
Modulus of rupture after heating: 24 h at 110°C		PRE R28	80	120	170	130	135	190	70	120	80	70	
Modulus of rupture after heating: 5 h at 1.000°C		PRE R28	80	170	70	180	90	170	180	165	205	200	
Modulus of rupture after heating: 5 h at max. service temperature		PRE R28	100	120	100	180	100	140	140	145	290	-	
Thermal conductivity at 500°C	W/mK	PRE R32	1,12	1,54	1,70	1,15	1,15	-	3,80	1,51	8,00	5,33	
Thermal conductivity at 1.000°C		PRE R32	1,33	1,50	1,01	1,18	1,75	2,32	4,00	1,45	6,73	4,76	
Application method			Vibrating							Self flowing			
Application method			Main trough safety lining							-	-	-	-

Gunning masses

PRODUCT			ALOGUN							
			CF 44	F 44 LI	F 44 LIW	BF 40	BF 50	BF 52	BF 525	BF 57
Main component			Chamotte				Chamotte andalusite	Chamotte	Mullitic chamotte	
CHEMICAL ANALYSIS (on raw materials oxides)										
Al ₂ O ₃	%	PRE R24	46,0	51,0	51,0	47,5	55,0	52,5	53,8	58,0
SiO ₂		PRE R24	35,5	38,5	38,5	45,5	35,0	38,0	37,0	33,0
Fe ₂ O ₃		PRE R24	4,0	1,3	1,3	0,8	0,8	0,6	0,6	0,6
TiO ₂		PRE R24	1,4	0,7	0,7	0,7	0,8	1,5	-	1,4
CaO		PRE R24	11,5	7,7	7,7	4,0	7,6	6,5	6,9	7,7
PHYSICAL PROPERTIES										
Max. service temperature	°C	(**)	1.280	1.350	1.350	1.500	1.500	1.500	1.500	1.500
Quantity required	t/m ³	(**)	1,90	2,06	2,22	2,00	2,20	2,10	2,06	2,12
P.L.C. after heating: 24 h at 110°C	%	PRE R28	± 0,20	-	-	± 0,05	± 0,10	± 0,05	- 0,05	± 0,05
P.L.C. after heating: 5 h at 1.000°C		PRE R28	- 0,20	-	-	- 0,10	± 0,20	-0,15	- 0,20	- 0,30
P.L.C. after heating: 5 h at max. service temperature		PRE R28	- 0,80	-	-	- 0,03	- 0,50	1,50	0,40	± 0,50
Bulk density after heating: 24 h at 110°C	gr/cm ³	PRE R9	2,10	2,16	2,22	2,07	2,20	-	2,09	2,18
Bulk density after heating: 5 h at 1.000°C		PRE R9	1,90	-	-	2,00	2,15	2,14	-	2,10
Bulk density after heating: 5 h at max. service temperature		PRE R9	1,85	-	-	2,04	2,25	-	-	-
Cold crushing strength after heating: 24 h at 110°C	kg/cm ²	PRE R28	550	630	850	400	650	950	850	600
Cold crushing strength after heating: 5 h at 1.000°C		PRE R28	450	-	-	320	550	410	450	500
Cold crushing strength after heating: 5 h at 1.000°C		PRE R28	500	-	-	610	700	750	650	400
Modulus of rupture after heating: 24 h at 110°C		PRE R28	60	65	75	35	70	70	65	60
Modulus of rupture after heating: 5 h at 1.000°C		PRE R28	50	-	-	10	50	10	30	55
Modulus of rupture after heating: 5 h at max. service temperature		PRE R28	50	-	-	90	90	110	90	55
Characteristics			-	CO resistance			-	CO resistance		
			-	-	(*)	-	-			
Application method			Gunning							

(*) Alogun F44LI with metallic needles added

(**) Internal method

Injection masses

PRODUCT			ALOJET			
			BL 50	BL 48	BL 90 P	BL 90 F
Main component			Chamotte	Tabular alumina	Tabular alumina	Tabular alumina
CHEMICAL ANALYSIS (on raw materials oxides)						
Al ₂ O ₃	%	PRE R24	53,5	91,0	92,0	91,0
SiO ₂		PRE R24	41,0	6,5	6,5	6,5
Fe ₂ O ₃		PRE R24	0,80	0,05	0,05	0,05
P ₂ O ₅		PRE R24	2,2	1,7	5,0	2,0
PHYSICAL PROPERTIES						
Grain size max.	mm	PRE R25	0,2	0,2	0,2	0,5
Max. service temperature	°C	(*)	1.500	1.500	1.600	1.500
Quantity required	t/m ³	(*)	2,35	2,45	2,50	2,58
Water required	%	PRE R26	5,5	5,0	5,0	7,0
P.L.C. after heating: 5 h at 800°C		PRE R28	- 0,45	- 0,20	± 0,04	- 0,20
P.L.C. after heating: 5 h at 1.200°C		PRE R28	+ 0,20	+ 0,20	0,60	-
Bulk density after heating: 5 h at 800°C	gr/cm ³	PRE R9	2,36	2,46	2,66	2,63
Bulk density after heating: 5 h at 1.200°C		PRE R9	2,37	2,45	2,61	-
Modulus of rupture after heating: 24 h at 800°C	kg/cm ²	PRE R28	80	120	170	70
Modulus of rupture after heating: 5 h at 1.200°C		PRE R28	80	170	70	200
Application method			With special pump			
Main application			Safety lining			

(*) Internal method

Iron trough

With increases in blast furnace capacity, top pressure, tapping speed and volume the service conditions of blast furnace iron troughs have become more severe.

Accordingly higher grades of refractories are used not only in the main runner (fixed or mobile) but also in the slag and pig iron runners.

Our company, which has long experience in the rammed lining, is producing and marketing lining for installation by vibration forming or casting.



Ultra low cement castables

PRODUCT			VIBRORUN						
			8037	80375	SC 75	ML 75	PRL 75	751 G	
Main component			Corundum silicon carbide carbon		Silicon carbide carbonio	Spinel silicon carbide	Bauxite silicon carbide carbon		
CHEMICAL ANALYSIS (on raw materials oxides)									
Al ₂ O ₃	%	PRE R24	70,4	65,5	17,5	71,0	62,0	75,5	
MgO		PRE R24	-	-	-	8,0	-	-	
CaO		PRE R24	0,8	0,9	-	-	0,7	0,7	
SiO ₂		PRE R24	3,0	-	3,5	3,0	5,7	6,5	
Fe ₂ O ₃		PRE R24	0,2	0,3	-	-	-	-	
TiO ₂		PRE R24	-	-	-	-	-	-	
SiC + C		PRE R24	22,5	27,5	75,0	15,5	27,5	13,0	
Metallic addition		PRE R24	Si	Si	Si	Si	Si	Si	
PHYSICAL PROPERTIES									
Max. service temperature	°C	(*)	1.650	1.650	1.650	1.650	1.650	1.650	
Quantity required	t/m ³	(*)	3,10	3,10	2,65	2,95	2,81	2,83	
Water required	%	PRE R26	3,5 ÷ 4,0	3,5 ÷ 4,0	4,5 ÷ 5,2	4,2 ÷ 4,9	4,0 ÷ 4,5	4,5	
P.L.C. after heating: 5 h at 1.000°C	%	PRE R28	± 0,05	± 0,10	± 0,20	± 0,10	± 0,05	- 0,10	
P.L.C. after heating: 5 h at max. service temperature		PRE R28	+ 0,15	± 0,30	± 0,20	± 0,05	+ 0,50	+ 0,40	
Bulk density after heating: 24 h at 110°C	gr/cm ³	PRE R9	3,12	3,15	2,66	2,98	2,87	2,88	
Bulk density after heating: 5 h at 1.000°C		PRE R9	3,09	3,12	2,65	2,94	2,83	2,86	
Bulk density after heating: 5 h at max. service temperature		PRE R9	3,03	3,11	2,67	2,99	2,79	2,84	
Cold crushing strength after heating: 24 h at 110°C	kg/cm ²	PRE R28	750	830	338	427	500	360	
Cold crushing strength after heating: 5 h at 1.000°C		PRE R28	1.300	920	501	649	350	220	
Cold crushing strength after heating: 5 h at max. service temperature		PRE R28	700	1.200	796	813	650	700	
Modulus of rupture after heating: 24 h at 110°C		PRE R28	40	90	37	39	45	50	
Modulus of rupture after heating: 5 h at 1.000°C		PRE R28	55	40	65	39	30	45	
Modulus of rupture after heating: 5 h at max. service temperature		PRE R28	50	100	178	85	80	95	
Thermal conductivity at 500°C	W/mK	PRE R32	8,47	8,50	-	-	-	-	
Thermal conductivity at 1.000°C		PRE R32	7,54	7,60	-	-	-	-	
Application method	Vibration								
Main Application			Main trough	Slag line main trough	Iron line main trough	Slag runner	Iron runner		

Special gunning masses

PRODUCT			ALOGUN				ALOCRETE	
			73 KBS	KSC 181	76 KS	091	80 S	SL 75
Main component			Bauxite silicon carbide carbon		Corundum silicon carbide carbon			Silicon carbide carbon
CHEMICAL ANALYSIS (on raw materials oxides)								
Al ₂ O ₃	%	PRE R24	70,0	62,0	64,7	50,0	70,0	18,5
CaO		PRE R24	3,7	1,8	3,7	0,3	0,3	-
SiO ₂		PRE R24	8,5	7,4	6,8	12,3	7,0	2,3
Fe ₂ O ₃		PRE R24	0,8	0,9	0,2	0,3	0,1	0,1
TiO ₂		PRE R24	-	-	-	-	-	-
SiC + C		PRE R24	+ 14,5	+ 25,0	+ 21,0	+ 27,0	+ 22,5	76,0
PHYSICAL PROPERTIES								
Max. service temperature	°C	(*)	1.650	1.700	1.700	1.650	1.600	1.600
Quantity required	t/m ³	(*)	2,50	2,50	2,55	2,43	3,00	2,54
P.L.C. after heating: 24 h at 110°C	%	PRE R28	- 0,3	-	- 0,1	- 0,1	-	-
P.L.C. after heating: 5 h at 1.000°C		PRE R28	- 0,30	± 0,20	- 0,20	± 0,10	0,06	-
P.L.C. after heating: 5 h at 1.550°C		PRE R28	± 0,20	± 0,60	± 0,20	+ 0,70	0,06	-
Bulk density after heating: 24 h a 110°C	gr/cm ³	PRE R9	2,39	2,52	2,46	-	2,85	2,56
Bulk density after heating: 5 h a 1.000°C		PRE R9	2,30	2,44	2,39	2,40	2,84	2,54
Bulk density after heating: 5 h a 1.550°C		PRE R9	2,32	2,50	2,41	2,21	2,80	2,52
Bulk density after heating: 5 h a 1.550°C	kg/cm ²	PRE R28	200	200	250	-	300	380
Cold crushing strength after heating: 5 h at 1.000°C		PRE R28	180	210	165	130	750	740
Cold crushing strength after heating: 5 h at 1.550°C		PRE R28	80	250	100	50	910	770
Modulus of rupture after heating: 24 h a 110°C		PRE R28	30	50	40	-	30	20
Modulus of rupture after heating: 5 h a 1.000°C		PRE R28	30	30	30	-	85	130
Modulus of rupture after heating: 5 h a 1.550°C		PRE R28	20	35	25	-	55	120
Application method			Gunning				Shot creeting	

Ramming masses

PRODUCT			ALORAM			ALOPLAST
			XG 65 S	XG 90 S	XG 95 S	XG 90 S
Main component			Bauxite silicon carbide carbon	Bauxite Corundum silicon carbide carbon	Bauxite Corundum silicon carbide	Bauxite Corundum Silicon carbide
CHEMICAL ANALYSIS (on raw materials oxides)						
Al ₂ O ₃	%	PRE R24	51,0	52,0	60,0	80,4
MgO		PRE R24	-	-	-	0,2
CaO		PRE R24	-	-	-	0,6
SiO ₂		PRE R24	11,0	11,0	7,7	13,2
Fe ₂ O ₃		PRE R24	1,3	1,8	0,3	1,8
TiO ₂		PRE R24	-	-	-	3,2
SiC + C		PRE R24	+ 25	+ 24	+ 22	+ 20
PHYSICAL PROPERTIES						
Max. service temperature	°C	(*)	1.600	1.700	1.700	1.700
Quantity required	t/m ³	(*)	2,50	2,70	2,82	2,75
P.L.C. after heating: 24 h at 110°C	%	PRE R28	- 0,3	- 0,3	- 0,7	- 0,7
P.L.C. after heating: 5 h at 1.000°C		PRE R28	- 0,3	- 0,1	- 0,4	- 0,4
P.L.C. after heating: 5 h at max. service temperature		PRE R28	- 0,7	- 0,3	- 0,9	- 0,9
Bulk density after heating: 24 h at 110°C	gr/cm ³	PRE R9	2,40	2,50	2,67	2,40
Bulk density after heating: 5 h at 1.000°C		PRE R9	2,35	2,40	-	2,30
Bulk density after heating: 5 h at max. service temperature		PRE R9	2,30	2,30	-	2,20
Cold crushing strength after heating: 24 h at 110°C	kg/cm ²	PRE R28	120	100	100	50
Cold crushing strength after heating: 5 h at 1.000°C		PRE R28	200	140	-	100
Cold crushing strength after heating: 5 h at max. service temperature		PRE R28	100	140	-	70
Modulus of rupture after heating: 24 h at 110°C		PRE R28	20	10	-	20
Modulus of rupture after heating: 5 h at 1.000°C		PRE R28	15	10	-	10
Modulus of rupture after heating: 5 h at max. service temperature	PRE R28	15	10	-	15	
Thermal conductivity at 500°C	W/mK	PRE R32	1,98	2,06	2,00	2,00
Thermal conductivity at 1.000°C		PRE R32	2,15	2,41	2,35	2,35
Application method			Ramming			
Main application			Runners			



SANAC

www.sanac.com

Commercial Direction and Central Laboratory
17047 VADO LIGURE (SV) - Via Manzoni 10
phone +39 019 28951
fax +39 019 2160156/2161399



www.ilvaspa.com